

# GUARD TOUR SYSTEM











## User Manual



Professional Manufacturer of Guard Tour System

Since 2006

## MENU

1.  Auto-induction Guard Tour System ..... 2
2.  Auto-induction LCD Display Guard Clocking System ..... 5
3.  Strong Lighting Guard Tour System ..... 8
4.  LCD & Lighting Guard Tour System ..... 11
5.  Auto-induction Guard Tour System ..... 14
6.  Touch Torch Guard Tour System ..... 18
7.  Auto-induction Guard Tour System ..... 22
8.  Wireless communication Guard Tour Reader ..... 27
9.  LED lighting Guard Patrol Stick ..... 36
10.  Accessories Introduction ..... 41
11.  Software installation & set-up ..... 42

## System composition

### Supplied Accessories

#### Accessories included with the device

- 1 Charger;
- 2 Silicone case;
- 3 User manual;
- 4 Software disk;
- 5 USB cable.

#### \*Accessories recommended for the device

- 6 Check point;
- 7 Staff ID tag;
- 8 PC/laptop;
- 9 Printer.

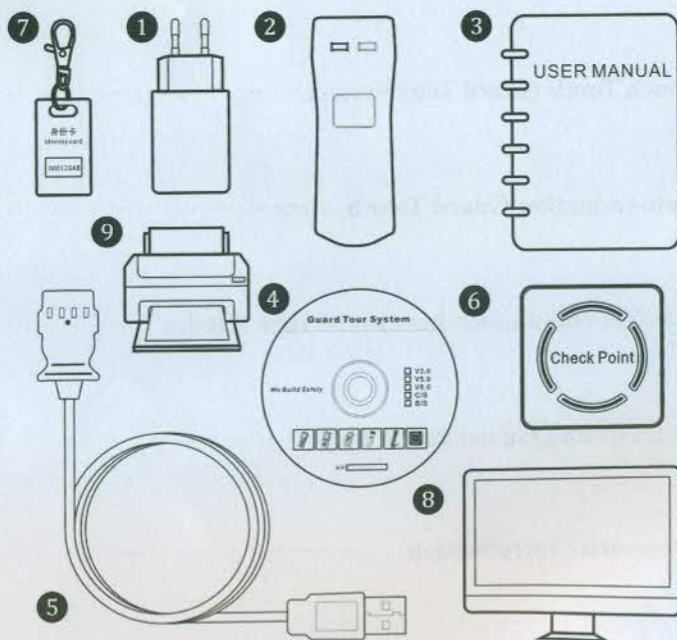

## 1. Auto-induction Guard Tour System

### 1.1 General features

- **Read Method:** Automatic sensors and Non-touch reading of RFID tag.
- **Structure:** Metal structure, waterproof, durable, resistant to high and low temperatures.
- **Direction:** LED flash and vibration.
- **Card-reading Technology:** Switzerland EM induction card-reading technology.
- **Storage Capacity:** 80,000pcs.
- **Impact record function :** Record impact logs up to 32,000pcs.
- **Date Safety:** Data can be stored for 30 years without power.
- **High speed download:** No need to install USB driver , faster and more stable communication speed .
- **Battery:** Built-in rechargeable lithium battery.
- **Communication:** Pogo pin USB contacts.

### 1.2 Production introduction

This guard tour reader work with rfid technology, is drop resistant, waterproof, shockproof. No need wiring and very simple for operation. There is real time built-in clock inside of device , can generate time stamp automatically once the reader scan rfid tags . Meanwhile, it work with USB cable to download data , no need to purchase download station additionally , low purchase cost .

Besides, this model is with impact recording function, while the device is been dropped or beat by force during usage, the device will record the impact time automatically, which is very helpful for supervisor to check the impact history of reader .

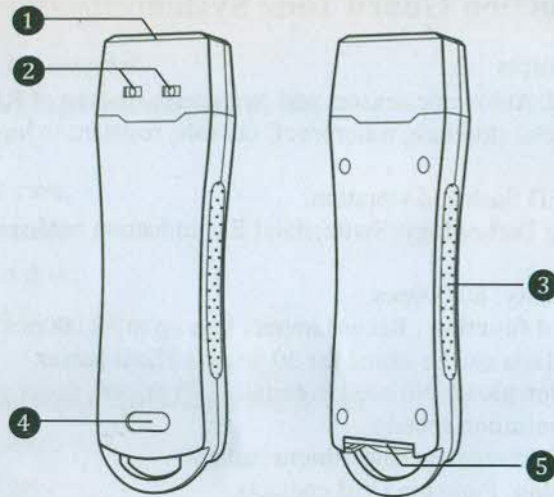

- ① Sensor area;
- ② LED indicator;
- ③ Anti-slide area;
- ④ Label Area;
- ⑤ USB port.

### 1.3 How to use

How to turn on the device: This reader work with built-in battery , so the factory mode is standby.

How to scan tags: Closing to the check point with the black head of reader, there will be a vibration with 3 times blue light flickers ,which means scan tag successfully.



### Impact records:

While the reader is subjected to an external force or dropped, the red and blue light will flash 3 times alternately, and reader will record the impact time . Impact record can be queried at software. Which is very helpful to query the impact history of reader.

**Delete data:** If there are 3 times vibration and 3 times red light flicker while scan tags, which means the memory of reader is full. Please donwload and clear data for normal use again.

### 1.4 How to charge the battery

The device can detect battery voltage automatically, when low battery , there will be 10 times red light flicker , which means device is under low battery mode now, please charge the battery soon by connecting USB cable .

During the battery charging, the red light flashing at different frequencies according along with voltage change, the lower the voltage, the faster the flash. The light will turn to blue while fully charged .

### 1.5 Failure and Solutions

Problem	Reason	Handling method
Vibrate 6 times, and red light flickers 6 times	Time error	Connect patrol reader with computer , click "Update time"
Vibrate 3 times, and red light flickers 3 times	Memory is full	Connect patrol reader with computer, save data to software first and click " clear data"
Red light flickers 10 times	Low battery	Charge the patrol reader with USB cable or wall charger

## 2. Auto-induction LCD Display Guard Clocking System

### 2.1 General features

- **Read Method:** Automatic sensors and Non-touch reading of RFID tag.
- **Physical:** Metal structure, waterproof, durable, resistant to high and low temperatures
- **Direction:** LED flash, LCD display and vibration.
- **LCD screen:** LCD screen display tags ID, date & time, memory space, low battery prompt and other while scanning tags.
- **Supported language:** Simplified and traditional Chinese, English, French and other languages (tailor made).
- **Card-reading Technology:** Switzerland EM induction card-reading technology.
- **Storage Capacity:** 80,000pcs
- **Impact record function :** Record impact logs up to 32,000pcs
- **Date Safety:** Data can be stored for 30 years without power.
- **High speed download:** No need to install USB driver , faster and more stable communication speed .
- **Battery :** Built-in rechargeable lithium battery
- **Communication:** Pogo pin USB contacts

### 2.2 General introduction

This guard tour reader work with rfid technology ,is drop resistant, waterproof, shockproof. No need wiring and very simple for operation . There is real time built-in clock inside of device , can generate time stamp automatically once the reader scan rfid tags . This model is with a little screen ,can display records capacity, rfid tags ID number ,date& time , low battery prompt and so on. Meanwhile , it work with USB cable to download data , no need to purchase download station additionally , low purchase cost .

Besides ,this model is with impact recording function, while the device is been dropped or beat by force during usage, the device will record the impact time automatically, which is very helpful for supervisor to check the impact history of reader .

### 2.3 Device introduction

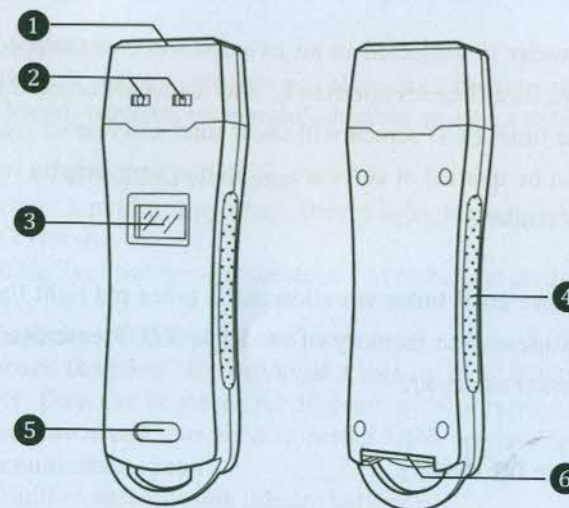

- ① Sensor area;
- ② LED indicator;
- ③ Display(can display tags ID, scanning time & date, memory , low battery prompt);
- ④ Anti-slide area;
- ⑤ Label Area;
- ⑥ USB port;

### 2.4 How to use

How to turn on the device : This reader work with built-in battery , so the factory mode is standby.

How to scan tags: Closing to the check point with the black head of reader , there will be a vibration with 3 times blue light flickers , and LCD screen will display tag ID, time and memory space ,which means scan tag successfully.



## Impact records:

While the reader is subjected to an external force or dropped, the red and blue light will flash 3 times alternately, and reader will record the impact time. At the same time, LCD screen will show time and impact record count. Impact record can be queried at software. Which is very helpful to query the impact history of reader.

**Delete data:** If there are 3 times vibration and 3 times red light flicker while scan tags, which means the memory of reader is full. Please download and clear data for normal use again.

## 2.5 How to charge the battery

The device can detect battery voltage automatically, when low battery, there will be 10 times red light flicker, which means device is under low battery mode now, please charge the battery soon by connecting USB cable.

During the battery charging, the red light flashing at different frequencies according along with voltage change, the lower the voltage, the faster the flash. The light will turn to blue while fully charged.

## 2.6 Failure and Solutions

Problem	Reason	Handling method
Vibrate 6 times, and red light flickers 6 times	Time error	Connect patrol reader with computer, click "Update time"
Vibrate 3 times, and red light flickers 3 times	Memory is full	Connect patrol reader with computer, save data to software first and click "clear data"
Red light flickers 10 times	Low battery	Charge the reader with USB cable

## 3. Strong Lighting Guard Tour System

### 3.1 General features

- **Read Method:** Automatic sensors and Non-touch reading of RFID tag.
- **Physical:** Metal structure, waterproof, durable, resistant to high and low temperatures
- **Direction:** LED flash and vibration.
- **LED lighting:** 5 modes supported. Bright light, normal light, low light, strobe and SOS modes.
- **Card-reading Technology:** Switzerland EM induction card-reading technology.
- **Storage Capacity:** 80,000 pcs
- **Impact record function:** Record impact logs up to 32,000 pcs
- **Date Safety:** Data can be stored for 30 years without power.
- **High speed download:** No need to install USB driver, faster and more stable communication speed.
- **Battery:** Built-in rechargeable lithium battery
- **Communication:** Pogo pin USB contacts

### 3.2 Production introduction

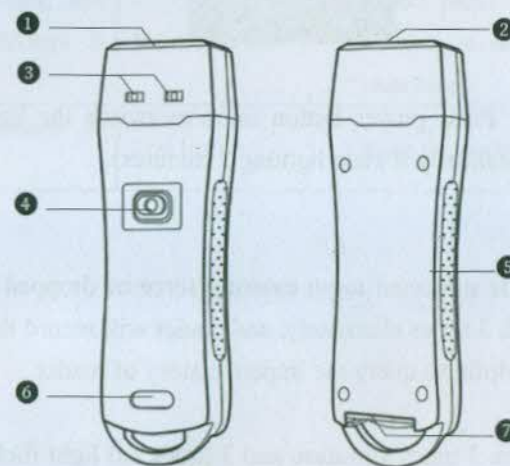

- ① Sensor area;
- ② LED lamp;
- ③ LED indicator;
- ④ Lighting switch;
- ⑤ Anti-slide area;
- ⑥ Label Area;
- ⑦ USB port.

### 3.3 How to use

How to turn on the device : This reader work with built-in battery , so the factory mode is standby.

How to scan tags: Closing to the check point with the black head of reader , there will be a vibration with 3 times blue light flickers , which means scan tag successfully.

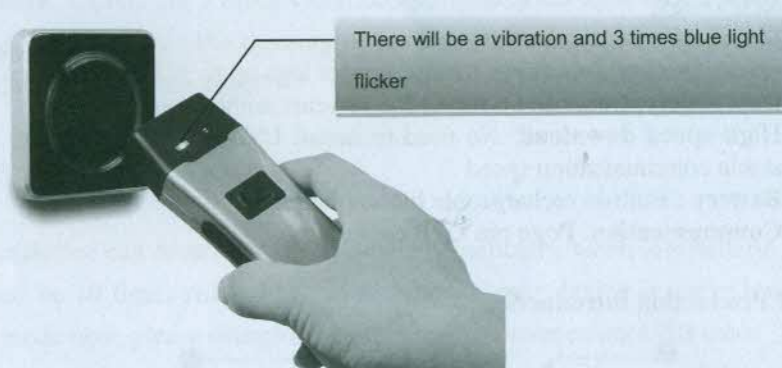

**LED light function :** Press power button once to switch the light mode ( Light will close automatically if keep lighting 2 minutes).

#### **Impact records:**

While the reader is subjected to an external force or dropped , the red and blue light will flash 3 times alternately, and reader will record the impact time . Which is very helpful to query the impact history of reader .

**Delete data:** If there are 3 times vibration and 3 times red light flicker while scan tags, which means the memory of reader is full. Please donwload and clear data for normal use again.

### 3.4 How to charge the battery

The device can detect battery voltage automatically, when low battery , there will be 10 times red light flicker , which means device is under low battery mode now, please charge the battery soon by connecting USB cable .

During the battery charging, the red light flashing at different frequencies according along with voltage change, the lower the voltage, the faster the flash . The light will turn to blue while fully charged .

### 3.5 Failure and Solutions

Problem	Reason	Handling method
Vibrate 6 times, and red light flickers 6 times	Time error	Connect patrol reader with computer , click "Update time"
Vibrate 3 times, and red light flickers 3 times	Memory is full	Connect patrol reader with computer, save data to software first and click " clear data"
Red light flickers 10 times	Low battery	Charge the reader with USB cable

## 4. LCD & Lighting Guard Tour System

### 4.1 General features

- **Read Method:** Automatic sensors and Non-touch reading of RFID tag.
- **Physical:** Metal structure, waterproof, durable, resistant to high and low temperatures
- **Direction:** LED flash ,screen display and vibration.
- **LED lighting :** 5 modes supported . Bright light, normal light, low light, strobe and SOS modes.
- **LCD display:** LCD screen display tags ID, date& time, memory space ,low battery prompt and other while scanning tags.
- **Card-reading Technology:** Switzerland EM induction card-reading technology.
- **Storage Capacity:** 80,000 pcs
- **Impact record function :** Record impact logs up to 32,000 pcs
- **Date Safety:** Data can be stored for 30 years without power.
- **High speed download:** No need to install USB driver , faster and more stable communication speed .
- **Battery :** Built-in rechargeable lithium battery
- **Communication:** Pogo pin USB contacts

### 4.2 Production introduction

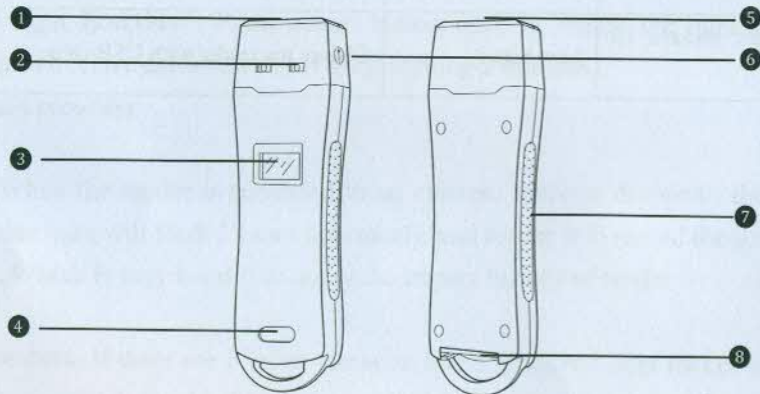

- |                |                  |                    |
|----------------|------------------|--------------------|
| 1 Sensor area; | 2 LED Indicator; | 3 Screen;          |
| 4 Label Area   | 5 LED Lamp;      | 6 Lighting Switch; |

### 4.3 How to use

How to turn on the device : This reader work with built-in battery , so the factory mode is standby.

How to scan tags: Closing to the check point with the black head of reader , there will be a vibration with 3 times blue light flickers together with LCD display tags ID , which means scan tag successfully.



### LED light function :

**Switch on :** Long pressing the torch icon lightly  and loose it till LED light on.

**Switch off:** Press torch icon for once  to switch off the light

**Light mode change :** Every time when model changed, then switch light to other mode.

## Impact records:

While the reader is subjected to an external force or dropped , the red and blue light will flash 3 times alternately, and reader will record the impact time . Which is very helpful to query the impact history of reader .

**Delete data:** If there are 3 times vibration and 3 times red light flicker while scan tags, which means the memory of reader is full. Please download and clear data for normal use again.

## 4.4 How to charge the battery

The device can detect battery voltage automatically, when low battery , there will be 10 times red light flicker , which means device is under low battery mode now, please charge the battery soon by connecting USB cable .

During the battery charging, the red light flashing at different frequencies according along with voltage change, the lower the voltage, the faster the flash . The light will turn to blue while fully charged .

## 4.5 Failure and Solutions

Problem	Reason	Handling method
Vibrate 6 times, and red light flickers 6 times	Time error	Connect patrol reader with computer , click "Update time"
Vibrate 3 times, and red light flickers 3 times	Memory is full	Connect patrol reader with computer, save data to software first and click "clear data"
Red light flickers 10 times	Low battery	Charge the reader with USB cable

## 5. Auto-induction Guard Tour System

### System composition

#### Supplied Accessories

##### Accessories included with the device

- 1 USB cable (A or B);
- 2 User manual;
- 3 Software disk;

##### \*Accessories recommended for the device

- 4 Charger plug;
- 5 Check point;
- 6 Staff ID tag;
- 7 PC/laptop;
- 8 Printer.

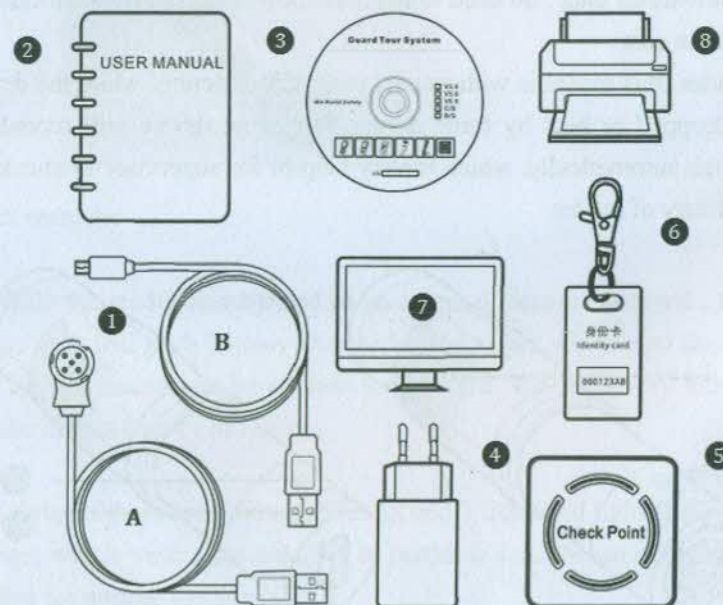

### 5.1 General features

- **Read Method:** Automatic sensors and Non-touch reading of RFID tag.
- **Structure:** flexible rubber shell.
- **Direction:** LED flash and vibration.
- **Card-reading Technology:** Switzerland EM induction card-reading technology.
- **Storage Capacity:** 40,000pcs.
- **Impact record function :** Record impact logs up to 8,000pcs.
- **Date Safety:** Data can be stored for 30 years without power.
- **High speed download:** No need to install USB driver , faster and more stable communication speed .
- **Battery :** Built-in rechargeable lithium battery.
- **Communication:** Pogo pin USB contacts or Mini USB contacts optional.

### 5.2 Production introduction

This guard tour reader work with rfid technology ,is drop resistant, waterproof, shockproof. No need wiring and very simple for operation . There is real time built-in clock inside of device , can generate time stamp automatically once the reader scan rfid tags . Meanwhile , it work with USB cable to download data , no need to purchase download station additionally , low purchase cost .

Besides ,this model is with impact recording function, while the device is been dropped or beat by force during usage, the device will record the impact time automatically, which is very helpful for supervisor to check the impact history of reader

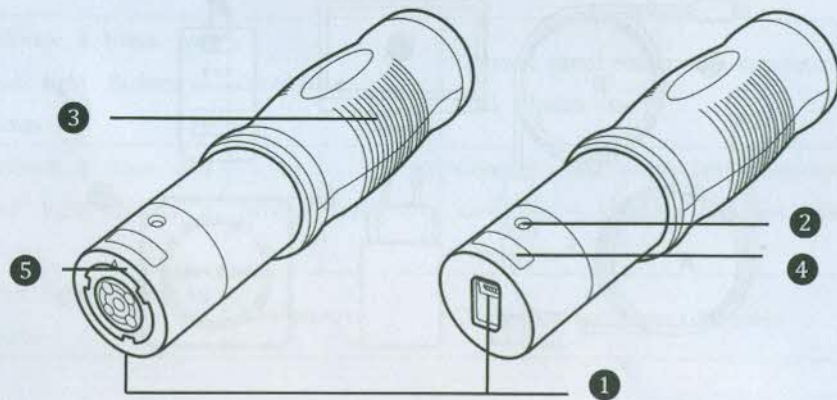

- 1 USB port;
- 2 LED indicator;
- 3 Anti-slide grip;
- 4 Label Area;
- 5 Sensor area.

### 5.3 How to use

How to turn on the device : This reader work with built-in battery , so the factory mode is standby.

How to scan tags: Closing to the check point with the black head of reader , there will be vibration with 3 times blue light flickers ,which means scan tag successfully.



### Impact records:

While the reader is subjected to an external force or dropped , the red and blue light will flash 3 times alternately, and reader will record the impact time . Impact record can be queried at software. Which is very helpful to query the impact history of reader .

**Delete data:** If there are 3 times vibration and 3 times red light flicker while scan tags, which means the memory of reader is full. Please donwload and clear data for normal use again.

## 5.4 How to charge the battery

The device can detect battery voltage automatically, when low battery , there will be 10 times red light flicker , which means device is under low battery mode now, please charge the battery soon by connecting USB cable .

During the battery charging, the red light flashing at different frequencies according along with voltage change, the lower the voltage, the faster the flash . The light will turn to blue while fully charged .

## 5.5 Failure and Solutions

Problem	Reason	Handling method
Vibrate 6 times, and red light flickers 6 times	Time error	Connect patrol reader with computer , click "Update time"
Vibrate 3 times, and red light flickers 3 times	Memory is full	Connect patrol reader with computer, save data to software first and click " clear data"
Red light flickers 10 times	Low battery	Charge the patrol reader with USB cable or wall charger

## 6. Touch Torch Guard Tour System

### System composition

#### Supplied Accessories

##### Accessories included with the device

- ① USB cable;
- ② User manual;
- ③ Software disk;

##### \*Accessories recommended for the device

- ④ Check point;
- ⑤ Staff ID tag;
- ⑥ PC/laptop;
- ⑦ Printer.

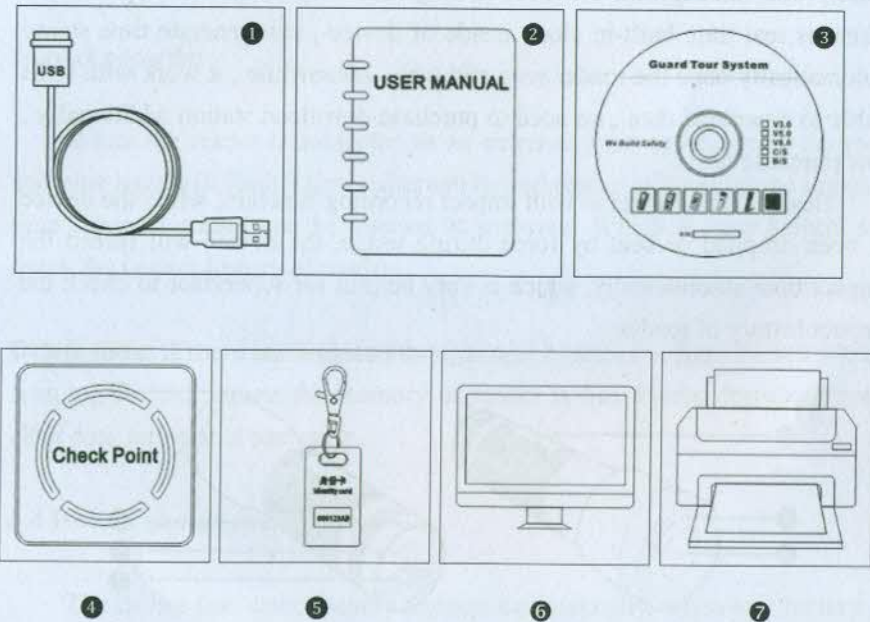

## 6.1 General features

- **Read Method:** Automatic sensors and Non-touch reading of RFID tag.
- **Structure:** Aluminum alloy.
- **Direction:** LED flash and vibration.
- **Card-reading Technology:** Switzerland EM induction card-reading technology.
- **Storage Capacity:** 80,000pcs.
- **Impact record function :** Record impact logs up to 32,000pcs.
- **Date Safety:** Data can be stored for 30 years without power.
- **High speed download:** No need to install USB driver , faster and more stable communication speed .
- **Battery :** Built-in rechargeable lithium battery.
- **Communication:** Magnetic USB port.
- **LED lighting:** Touch switch 5 modes LED lighting.

## 6.2 Production introduction

This guard tour reader work with rfid technology ,is drop resistant, waterproof, shockproof. No need wiring and very simple for operation . There is real time built-in clock inside of device , can generate time stamp automatically once the reader scan rfid tags . Meanwhile , it work with USB cable to download data , no need to purchase download station additionally , low purchase cost .

Besides ,this model is with impact recording function, while the device is been dropped or beat by force during usage, the device will record the impact time automatically, which is very helpful for supervisor to check the impact history of reader .

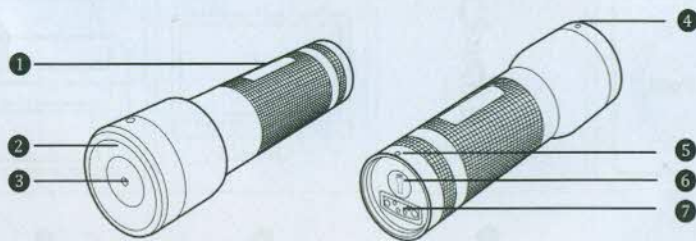

- ① Label area    ② RFID Sensor    ③ LED lamp    ④ LED Indicator  
⑤ Lanyard hole    ⑥ Lighting switch    ⑦ Magnetic Popo Pin USB Por

## 6.3 How to use

How to turn on the device : This reader work with built-in battery , so the factory mode is standby.

How to scan tags: Closing to the check point with the black head of reader , there will be vibration with 3 times blue light flickers ,which means scan tag successfully.

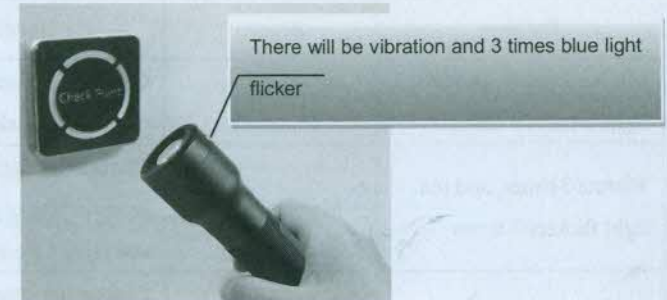

## Impact records:

While the reader is subjected to an external force or dropped , the red and blue light will flash 3 times alternately, and reader will record the impact time . Impact record can be queried at software. Which is very helpful to query the impact history of reader .

**Delete data:** If there are 3 times vibration and 3 times red light flicker while scan tags, which means the memory of reader is full. Please donwload and clear data for normal use again.

## 6.4 How to charge the battery

The device can detect battery voltage automatically, when low battery , there will be 10 times red light flicker , which means device is under low battery mode now, please charge the battery soon by connecting USB cable .

During the battery charging, the red light flashing at different frequencies according along with voltage change, the lower the voltage, the faster the flash . The light will turn to blue while fully charged .

### 6.5 Failure and Solutions

Problem	Reason	Handling method
Vibrate 6 times, and red light flickers 6 times	Time error	Connect patrol reader with computer , click "Update time"
Vibrate 3 times, and red light flickers 3 times	Memory is full	Connect patrol reader with computer, save data to software first and click " clear data"
Red light flickers 10 times	Low battery	Charge the patrol reader with USB cable or wall charger

## 7. Auto-induction Guard Tour System

### System composition

#### Supplied Accessories

##### Accessories included with the device

- ① Charger;
- ② Leather case;
- ③ User manual;
- ④ Software disk;
- ⑤ USB cable (A or B).

##### \*Accessories recommended for the device

- ⑥ Check point;
- ⑦ Staff ID tag;
- ⑧ PC/laptop;
- ⑨ Printer.

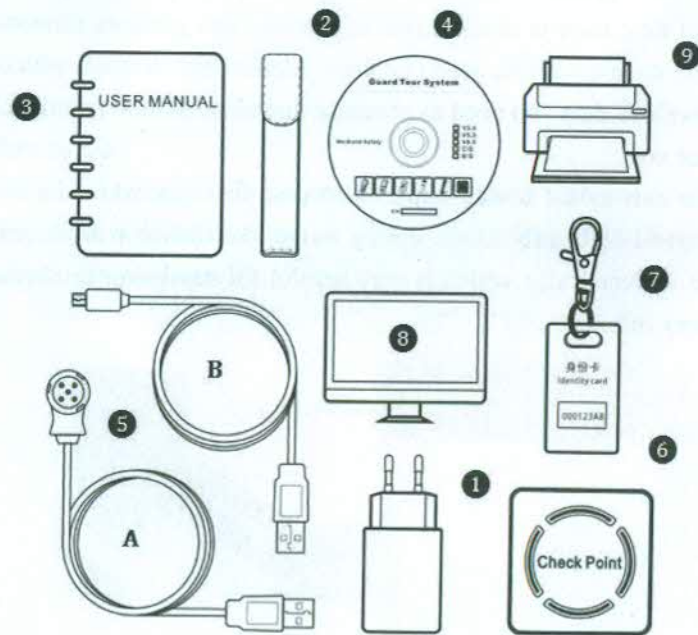

### 7.1 General features

- **Read Method:** Automatic sensors and Non-touch reading of RFID tag.
- **Structure:** Aluminum alloy structure, waterproof, durable, resistant to high and low temperatures.
- **Direction:** LED flash and vibration.
- **Card-reading Technology:** Switzerland EM induction card-reading technology.
- **Storage Capacity:** 80,000pcs.
- **Impact record function :** Record impact logs up to 32,000pcs.
- **Date Safety:** Data can be stored for 30 years without power.
- **High speed download:** No need to install USB driver , faster and more stable communication speed .
- **Battery :** Interchangeable & rechargeable lithium battery.
- **Communication:** Via USB cable.

### 7.2 Production introduction

This guard tour reader work with rfid technology ,is drop resistant, waterproof, shockproof. No need wiring and very simple for operation . There is real time built-in clock inside of device , can generate time stamp automatically once the reader scan rfid tags . Meanwhile , it work with USB cable to download data , no need to purchase download station additionally , low purchase cost .

Besides ,this model is with impact recording function, while the device is been dropped or beat by force during usage, the device will record the impact time automatically, which is very helpful for supervisor to check the impact history of reader .

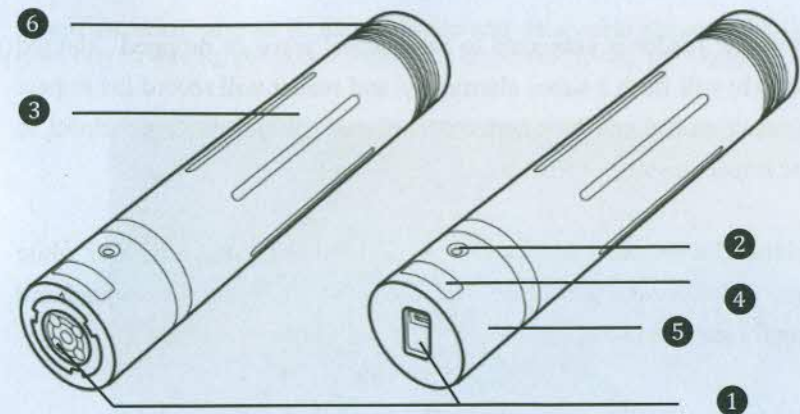

- 1 USB port;
- 2 LED indicator;
- 3 Anti-slide area;
- 4 Label Area;
- 5 Sensor area;
- 6 Battery cover.

### 7.3 How to use

How to scan tags: Closing to the check point with the black head of reader , there will be a vibration with 3 times blue light flickers ,which means scan tag successfully.



### Impact records:

While the reader is subjected to an external force or dropped , the red and blue light will flash 3 times alternately, and reader will record the impact time . Impact record can be queried at software. Which is very helpful to query the impact history of reader .

**Delete data:** If there are 3 times vibration and 3 times red light flicker while scan tags, which means the memory of reader is full. Please download and clear data for normal use again.

### 7.4 How to replace and charge the battery

The device can detect battery voltage automatically, there will be 10 times red light flicker when low battery ,please charge battery soon .

2 ways to charge battery :

**A. Charge battery with USB cable directly .** No need to take battery out , charge by connecting device with USB cable (the red light will flash at different frequencies according along with voltage change, the lower the voltage, the faster the flash . The light will turn to blue while fully charged).

**B. Charge with charger adapter** (Red light means charging, green light means fully charged or no battery inserted )



Please open the battery cover with anti-clockwise direction, and **please must pay attention to the positive and negative electrode of battery .**

### 7.5 How to connect USB cable

There are small arrows in patrol device and data cable, please make these 2 arrows corresponding and screw follow the direction "Lock" or "Open".



### 7.6 Failure and Solutions

Problem	Reason	Handling method
Vibrate 6 times, and red light flickers 6 times	Time error	Connect patrol reader with computer , click "Update time"
Vibrate 3 times, and red light flickers 3 times	Memory is full	Connect patrol reader with computer, save data to software first and click " clear data"
Red light flickers 10 times	Low battery	Charge the patrol reader with USB cable or wall charger

## 8. Wireless communication Guard Tour Reader

### System composition

#### Supplied Accessories

##### Accessories included with the device

- ① Holder;
- ② CR123A battery (for Pattern A only);
- ③ User manual;
- ④ Software disk;
- ⑤ USB cable (for Pattern B only)

##### \*Accessories recommended for the device

- ⑥ Check point;
- ⑦ Staff ID tag;
- ⑧ PC/laptop;
- ⑨ Printer.

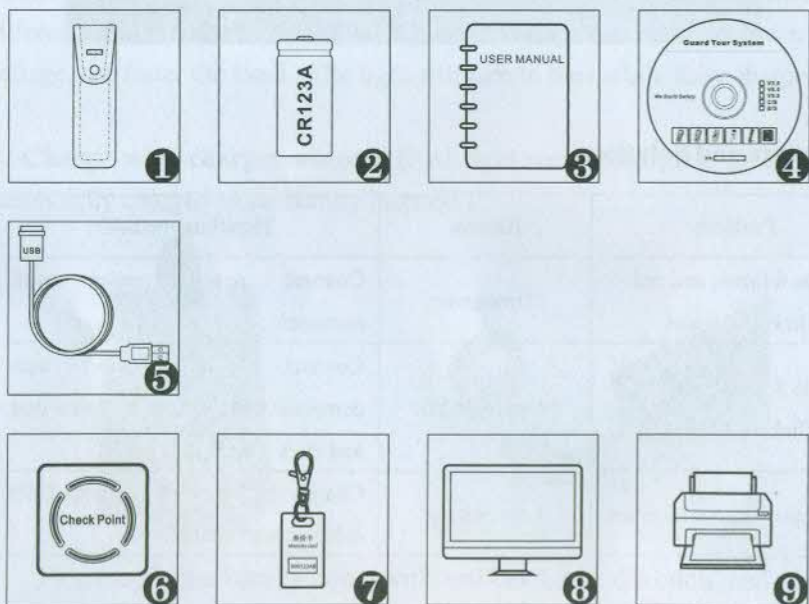

## 8.1 Device Introduction

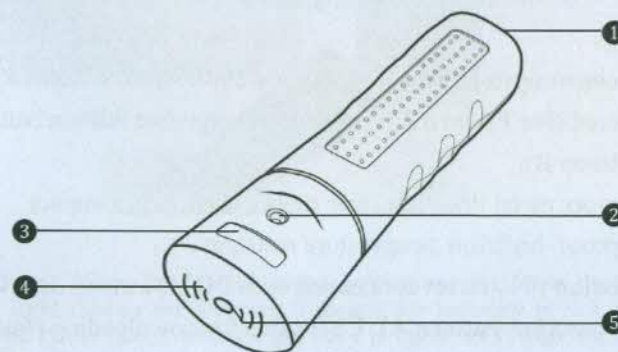

- ① Battery;
- ② LED indicator;
- ③ Label Area;
- ④ Sensor area;
- ⑤ Buzzer.

### Pattern A

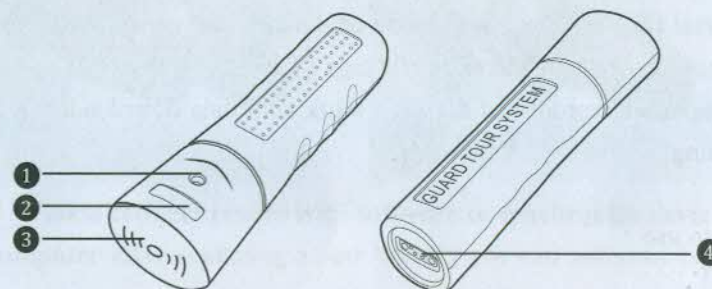

- ① LED Indicator
- ② Label Area
- ③ Sensor
- ④ Magnetic USB Port

### Pattern B

## 8.2 General features

- **Read Method:** Auto-induction technology, non-touch scanning. Read 125khz RFID tags
- **Super lower consumption:** Standby power is 100UA, 3.0V camera battery can powered (**for Pattern A**). Built-in rechargeable lithium battery powered(**for Pattern B**).
- **Structure:** Super metal liner , flexible rubber shell, super impact resistant ,shake-proof, high/low temperature resistant .
- **Data transmission :** No direct connection with PC, download data via data downloader base(**for Pattern A**). USB cable for downloading (**for Pattern B**).
- **Operation prompt :** Beep sounds(vibration) and led flicker.
- **Memory capacity:** 8000 logs.

## 8.3 Product introduction

This guard tour reader work with rfid technology ,is drop resistant, waterproof, shockproof. No need wiring and very simple for operation . There is real time built-in clock inside of device , can generate time stamp automatically once the reader scan rfid tags . There is no any USB port from reader , super waterproof and rugged . Work with data downloader for data downloading .

## 8.4 How to use

**How to scan tags:** Closing to the check point with the black head of reader , there will be a beep sound (vibration) together with 3 times blue light flickers ,which means scan tag successfully.

There will be once beep sound (vibration) and 3 times blue led flicker while scanning tags successfully.

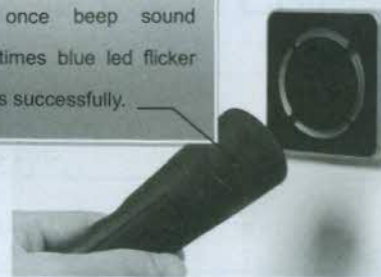

**Delete data:** When the buzzer beeps (vibration) for three times and the red indicator light flashes for 3 times, it means the memory is full, please connect device with PC to check whether memory is up to 8000 logs, then click " delete data " with software .

**Low battery:** The patrol device can detect the battery power automatically, while low battery, there will 6 times beeps sound (vibration) together with 6 times red light flicker. Please replace battery immediately.

**How to replace battery (for Pattern A) :** Tear off the bottom sticker at battery cover , use tweezers or nipper pliers to unscrew battery cover in anti-clockwise direction with plugging into 2 holes .



**Notice :** Please connect reader with software to synchronize device clock with computer after replacing a new battery , or can not scan tags since time error .

## 8.5 Failure and Solutions

Problem	Reason	Handling method
The buzzer beeps (vibration) 6 times, the red and green lights flash for six times	Time error	Synchronize the time and date of the patrol device with the computer.
The buzzer beeps (vibration) 6 times, the red light flashes for six times	Low power	Change the new battery
The buzzer beeps (vibration) 3 times, and the red light flashes for three times	The memory is full	Download the data to the computer and delete the data from the patrol software

## 9. Wireless Date Transfer Communication Station

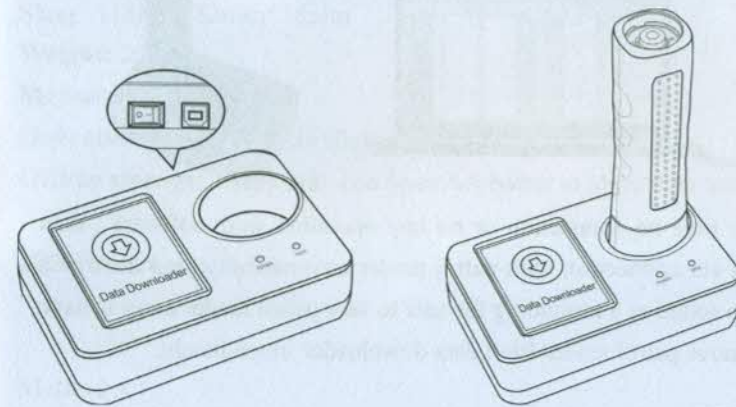

### 9.1 General features

It like a bridge to connect patrol device with computer . Powered by USB cable directly .

**Communication:** Wireless communication with patrol reader; USB connection with PC

**Size:** 118mm\*82mm\*36mm

**Weight:** 220g

**Memory :No**

**Operation prompt :** LED flicker

### 9.2 How to use

Connect Data downloader with PC, turn on power button (power light on), plug patrol reader to data downloader slot , there will be once beep sound means device is successfully connected with data downloader ,then go to software to download data or other communication operation. (There will be blue light on or flicker if mass data downloading )

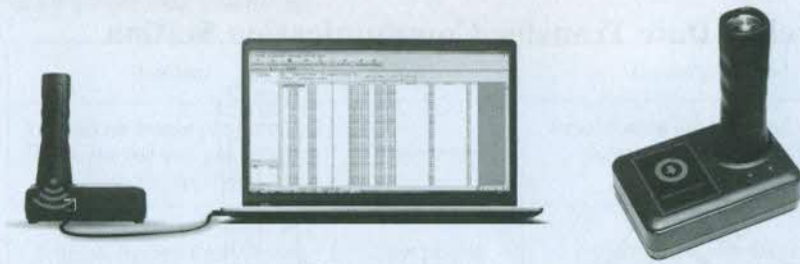

**Notice :** If long time no connection or no any operation from software , data downloader will cut connection with patrol reader automatically ,and there will be 10 times beep sound as a reminding for user to take patrol reader away to save power . Please move patrol reader from data downloader immediately.

## 10. Wireless data storage downloader communication station

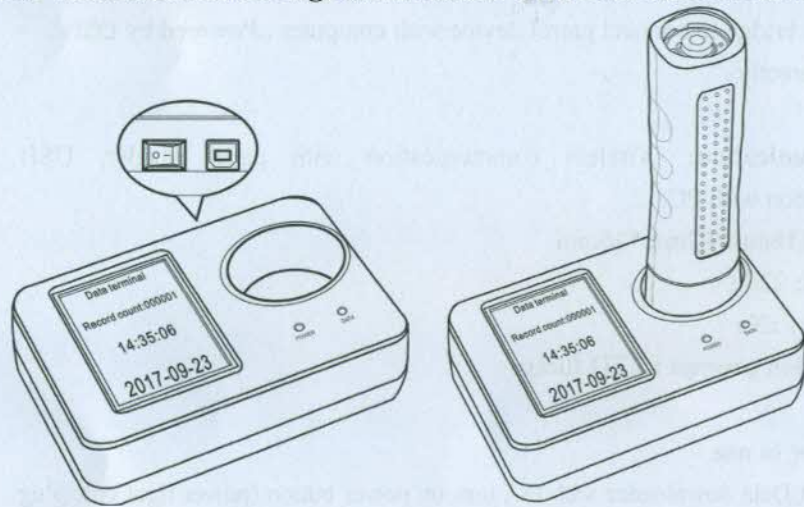

### 10.1 General features

It like a U disk to connect patrol device with computer . Powered by USB cable directly or 3pcs AA battery .Can work without PC to download data from patrol reader and store data temporarily.

**Communication:** Wireless communication with patrol reader; USB connection with PC

**Size:** 118mm\*82mm\*36mm

**Weight:** 220g

**Memory :**600,000 logs.

**Operation prompt :** LED flicker + LCD screen.

**Offline storage:** Yes, work with 3pcs AA batter to store data temporarily.

### 10.2 How to use

#### Method A :

Connect Data downloader with PC, turn on power button (power light on), plug patrol reader to data downloader slot , there will be once beep sound means device is successfully connected with data downloader then go to software to download data or other communication operation. (There will be blue light on or flicker if mass data downloading )



#### Method B:

Insert 3pcs AA battery , turn own power button (power light on), plug patrol reader to data downloader slot , there will be once beep sound means device is successfully connected with data downloader then go to software to download data or other communication operation. (There will be blue light on or flicker if mass data downloading )



**Notice :** If long time no connection or no any operation from software , data downloader will cut connection with patrol reader automatically ,and there will be 10 times beep sound as a reminding for user to take patrol reader away to save power . Please move patrol reader from data downloader immediately.

### 10.3 Failure and Solutions

Problem	Reason	Handling method
The indicator blue light flashes for 6 times continuously	The battery had been sitting too long	Connect device with software to synchronize time by clicking "set time".
The indicator red light flashes for 6 times continuously	The memory is full.	Connect device with software to download data and delete data from device
The indicator blue light flashes for 3 times continuously	Low power	Replace a new battery

## 11. LED lighting Guard Patrol Stick

### System composition

#### Supplied Accessories

##### Accessories included with the device

- 1 Charger;
- 2 Leather case;
- 3 User manual;
- 4 Software disk;
- 5 USB cable (A or B).

##### \*Accessories recommended for the device

- 6 Check point;
- 7 Staff ID tag;
- 8 PC/laptop;
- 9 Printer.

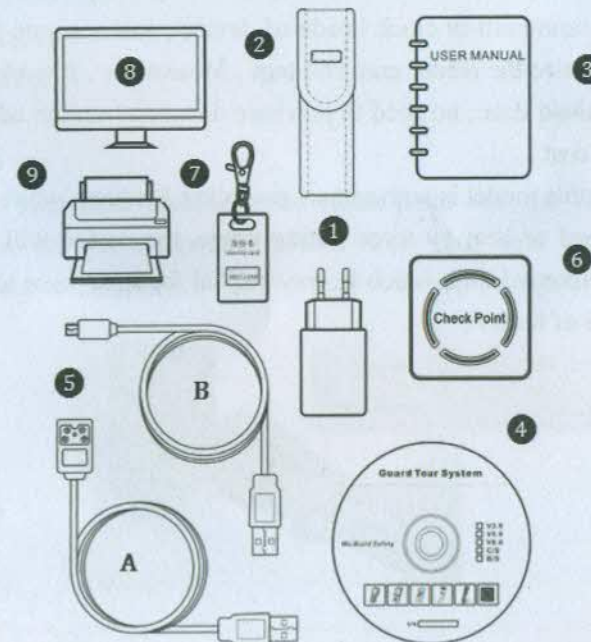

### 11.1 General features

- **Read Method:** Automatic sensors and Non-touch reading of RFID tag.
- **Structure:** Aluminum alloy structure, waterproof, durable, resistant to high and low temperatures.
- **Direction:** LED flash and vibration.
- **Card-reading Technology:** Switzerland EM induction card-reading technology.
- **Storage Capacity:** 80,000pcs.
- **Impact record function :** Record impact logs up to 32,000pcs.
- **Date Safety:** Data can be stored for 30 years without power.
- **High speed download:** No need to install USB driver , faster and more stable communication speed .
- **Battery :** Interchangeable & rechargeable lithium battery.
- **Communication:** Via USB cable.
- **LED lighting:** Strong LED lighting ,helpful for night patrolling.

### 11.2 Production introduction

This guard tour reader work with rfid technology ,is drop resistant, waterproof, shockproof. No need wiring and very simple for operation . There is real time built-in clock inside of device , can generate time stamp automatically once the reader scan rfid tags . Meanwhile , it work with USB cable to download data , no need to purchase download station additionally , low purchase cost .

Besides ,this model is with impact recording function, while the device is been dropped or beat by force during usage, the device will record the impact time automatically, which is very helpful for supervisor to check the impact history of reader .

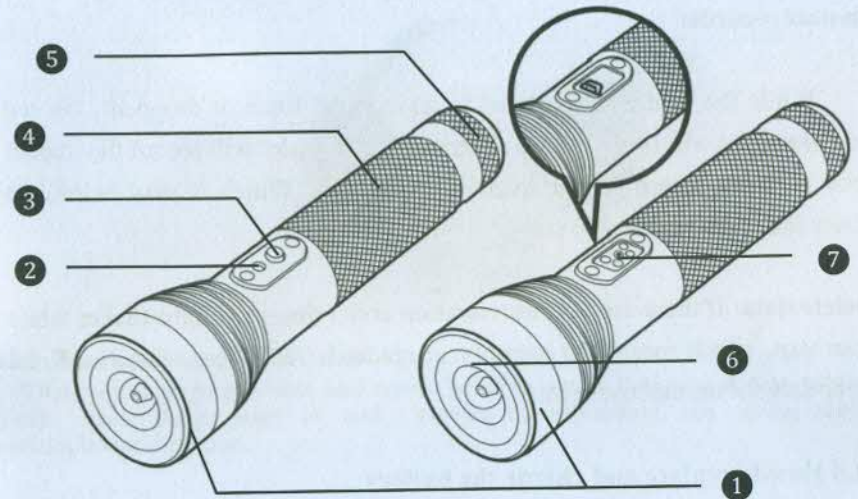

- 1 Sensor area;
- 2 LED indicator;
- 3 Torch light switch;
- 4 Anti-slide area;
- 5 Battery cover;
- 6 Lighting area;
- 7 USB port.

### 11.3 How to use

How to scan tags: Closing to the check point with the black head of reader , there will be a vibration with 3 times blue light flickers ,which means scan tag successfully.



### Impact records:

While the reader is subjected to an external force or dropped, the red and blue light will flash 3 times alternately, and reader will record the impact time. Impact record can be queried at software. Which is very helpful to query the impact history of reader.

**Delete data:** If there are 3 times vibration and 3 times red light flicker while scan tags, which means the memory of reader is full. Please download and clear data for normal use again.

### 11.4 How to replace and charge the battery

The device can detect battery voltage automatically, there will be 10 times red light flicker when low battery, please charge battery soon. 2 ways to charge battery:

**A. Charge battery with USB cable directly.** No need to take battery out, charge by connecting device with USB cable (the red light will flash at different frequencies according along with voltage change, the lower the voltage, the faster the flash. The light will turn to blue while fully charged).

**B. Charge with charger adapter.** (Red light means charging, green light means fully charged or no battery inserted)



Please open the battery cover with anti-clockwise direction, and please must pay attention to the positive and negative electrode of battery.



### 11.5 How to connect USB cable

There are 4 pogo pin dots and screw holes in patrol device and data cable, please make these pogo in and screws corresponding and screw with anticlockwise direction.

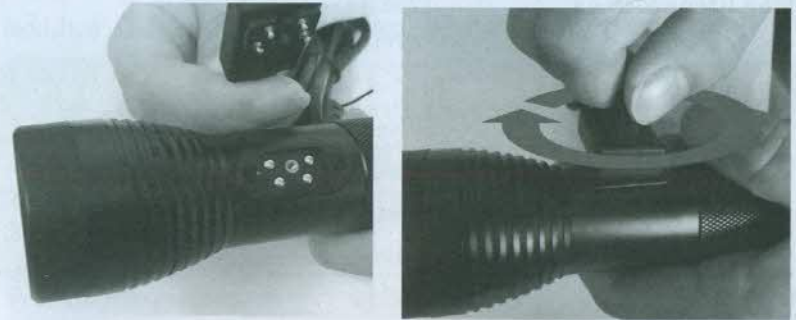

### 11.6 Failure and Solutions

Problem	Reason	Handling method
Vibrate 6 times, and red light flickers 6 times	Time error	Connect patrol reader with computer, click "Update time"
Vibrate 3 times, and red light flickers 3 times	Memory is full	Connect patrol reader with computer, save data to software first and click "clear data"
Red light flickers 10 times	Low battery	Charge the patrol reader with USB cable or wall charger

## 12. Accessories Introduction

### (1) Checkpoint (ask extra purchase)

Check point is use for marking patrol site , which is with chip inside , every check point is with global unique ID number (can't be modified) . Easy for installation, no need wiring , no need power supplied , can fixed with structural adhesive or screw. Can be used in many areas or even harsh environment such as rainy, snowy, icy , dusty and so on.

#### Specification:

Item	Data	Image
Working Frequency	125kHz	
Size	70*70*10mm	
Working Temperature	-40°C~85°C	
Life	20 years	
Color	Black (luminous at dark place )	
Net Weight	33g	
Reading Capacity	> 350,000pcs	

#### Installation

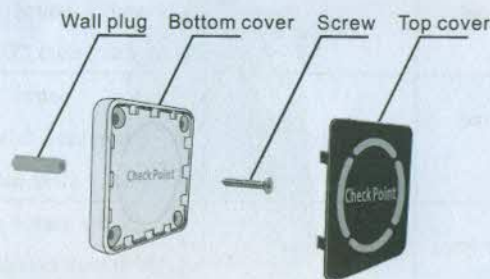

Step 1: Drill 6mm holes in the wall and knock in the wall plug;  
 Step 2: Use 2 or more screws to fix the bottom cover;  
 Step 3: Cover up the top cover.

### (2) Communication cable

It is used for connecting guard tour reader and software to transfer data. Easy operation and no need extra data downloader , save much cost.



- Full plastic shell, reliability and good looks;
- Wire communication, do not use power;  
The transmission speed is 115200Bps.

### (3) Staff ID card (ask extra purchase)

Staff ID cards are used to distinguish security officers identity. Which is with chip inside , every staff ID card is with global unique ID number (can't be modified) ,no need power supplied. While starting guard patrol or shift change , use patrol reader to scan the staff ID card as log in , then every time while scanning the check point , the data will be stored with format “ Who, When ,Where ” he did .**Device model with fingerprint function can ignore this parts , because it can use fingerprint as identity distinguish .**

Working frequency	125kHz	Image
Working Temperature	-40°C~+85°C	
Size	5.5*3CM	
Service life	20 years	
Reading capacity	350,000 times	

## 13. Software installation & set-up

Please refer to the manual in the software file.

## Guarantee card including guarantee items

### Product Maintenance Guarantee Card

Customer shall please fill in below content and keep it carefully after purchasing the device, in order to gain perfect after-service. Please read carefully the items given:

Customer name: \_\_\_\_\_ Customer contact Tel: \_\_\_\_\_  
Product model: \_\_\_\_\_ Device number: \_\_\_\_\_  
Purchase date: \_\_\_\_\_ Distributor: \_\_\_\_\_  
Invoice number: \_\_\_\_\_ Distributor stamp: \_\_\_\_\_

#### Notes and system maintenance

- 1) You should follow the regular operation rules, startup & shutdown the patrol in normal way, and you can only exit the patrol device after saving data, otherwise the data will be damaged.
- 2) Please recharge the battery when "low battery" prompt, otherwise you may lose or damage the data.
- 3) Read tag within the effective distance, the card reading is only successful when the device vibrates ,beeps or LED flashes.
- 4) The patrol software system should be operated by person with normal computer operation skills.
- 5) Non-professional person shouldn't disassemble any part of the patrol software or change/delete the related documents of this patrol software.
- 6) Contact the manufacture(after sale service) if the device cannot work normally, You'd better not handle the problem by yourself to avoid unnecessary trouble.

#### Customer service and technical support commitment

- 1) Free repair within 1 year, lifelong maintenance but charge for material required.
- 2) Purchasing time is up to the commercial invoice issued by the manufacture.
- 3) This guarantee is ended automatically if any following situation happens.

Users change or disassemble by themselves, or any other operations which destroy the completion of the patrol software.

Users fail to follow the proper operation instruction which results in partial or full damage.

Users can't offer the relative invoice or receipt.

- 4) Wherever you buy the device, you can get the after-sale service. We take great honor to serve you and solve all the problems in the shortest time.

Date	Maintenance records	Maintained by